

PORTABLE ADJ. HEIGHT WORKER STAND - PAHW-L-1924 APPROX WEIGHT: 41.96 lbs.
 DOES NOT INCLUDE WEIGHT OF POWER OR PACKAGING!!!

ANY ADDITIONS, DELETIONS, OR OMISSIONS MUST BE CORRECTED ON THIS DRAWING AS THIS DRAWING WILL BE CONSIDERED ALL INCLUSIVE

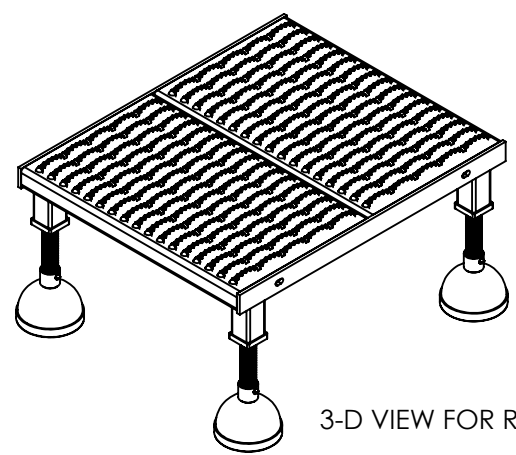

3-D VIEW FOR REFERENCE

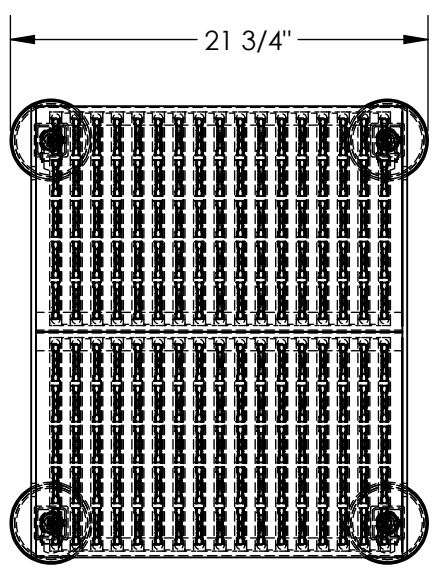
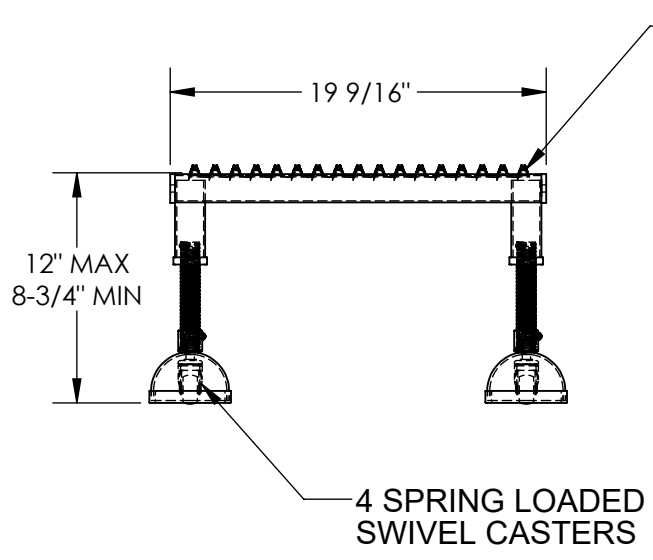

SERRATED STEEL PLATFORM FOR TRACTION

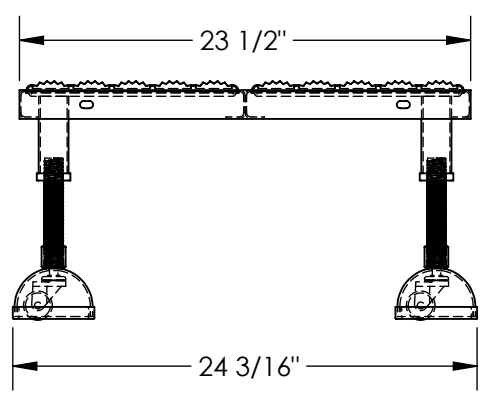

DIMENSION TOLERANCE ± 1/4"

ALL GRAPHICS PROVIDED ARE FOR REFERENCE ONLY. IF CERTAIN DIMENSIONS ARE CRITICAL PLEASE VERIFY THOSE DIMENSIONS WITH YOUR SALESPERSON

STANDARD FEATURES

- MODEL NUMBER IS PAHW-L-1924
- CAPACITY IS 500 LBS
- OVERALL WIDTH IS 21 3/4"
- USABLE WIDTH IS 19 9/16"
- OVERALL LENGTH IS 24 3/16"
- USABLE LENGTH IS 23 1/2"
- OVERALL HEIGHT IS 8-3/4" THRU 12"
- 4 ADJUSTABLE LENGTH LEGS
- 4 SPRING LOADED SWIVEL CASTERS
- TOUGH BAKED IN POWDER COATED YELLOW FINISH

A P P R O V A L	I, THE UNDERSIGNED, AGREE THAT THE PRODUCT AS REPRESENTED SATISFIES DESIGN AND DIMENSION REQUIREMENTS. I ALSO ACKNOWLEDGE MY DUTY TO CONFIRM PRODUCT AND INSTALLATION COMPLIANCE WITH ALL APPLICABLE FEDERAL, STATE AND LOCAL REGULATIONS AND STANDARDS.	
	UNITS REQUIRING APPROVAL DRAWINGS OR MODIFIED ARE NON-RETURNABLE	
	[] As drawn [] As marked	
	Signed: _____ Date: _____	
Printed Name: _____		
<i>LEAD TIME WILL START UPON RECEIPT OF SIGNED APPROVAL DRAWING</i>		

DISTRIBUTOR'S NAME:		P.O.#
VESTIL MANUFACTURING		X
		W.O.#
		X
DRAWN BY: MTS	DATE: 03/26/13	SALES: X
REFERENCE: X	SCALE: 1:10	FILE NAME:
QUOTED LEAD TIME: X	QUOTE # X	14-007-167